

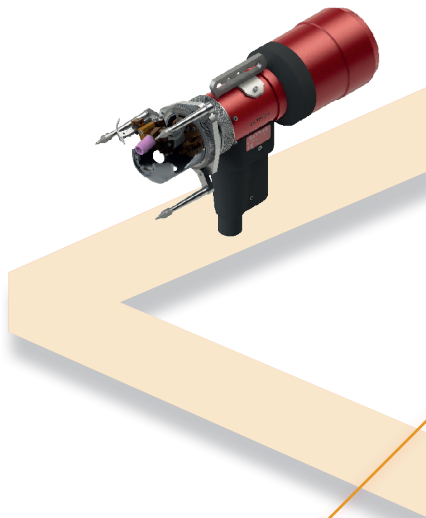

# SATP-80X



**Water Cooled**

**Tilting head**  
Water cooled with tilting wire

**Mandrel system**  
Concentric tightening from the inside of the tube

**Compatible With the SAXX generators**

**Flexibility**  
Head and wire adjustment trolley

**Wire holder 1 kg**

**Positioning stops**  
Adjustable stops for better tube sheet stability

**Electric motor with wire feed**

Welding range	
SATP-80X	∅ 10 - ∅ 80 mm 0.4 - 3 "



# SATP-80X

The SATP-80X covers virtually all common tube to tube sheet configurations in stainless steel as well as in titanium or black steel.



**AXXAIR**  
INNOVATIVE ORBITAL SOLUTIONS

## Technical characteristics:

- Rotating gas, current and cooling seal
- Tilting water cooled head
- Head and wire adjustment trolley
- Built-in rotating wire dispenser (Ø 0.8 mm)
- Wire speed from 0 to 1.5 m / min
- Cycle startup integrated in the handle for better ergonomics
- The head is fully cooled allowing a maximum welding current of 200A
- Specific mandrel with ball centring pushed by springs: precise positioning and quick installation.

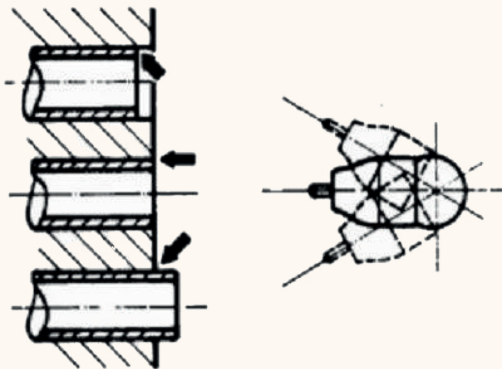
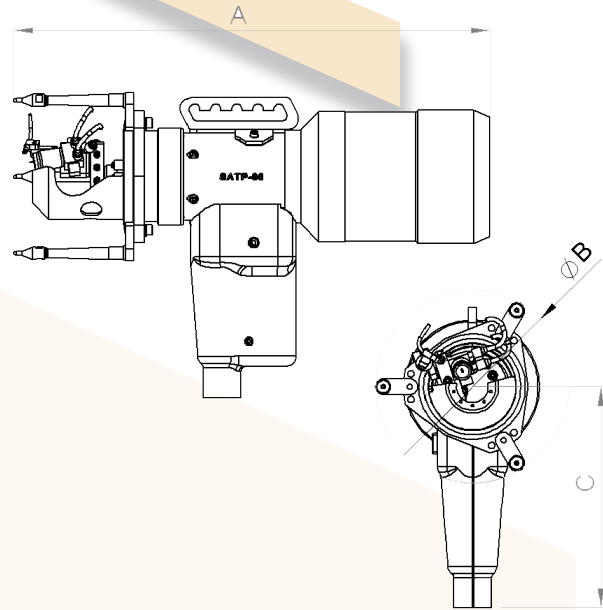

- 3 tube-to-tube sheet welding configurations
- Outside diameter of the straight torch tube: 12 - 82 mm
- External diameter of the tube if torch tilted at 30 °: 12 - 40 mm

Product Code	Description	Net weight (Without reel)	Ø wire	Max Wire Speed	Customs code	Dimensions (AxBxC mm)
SATP-80X	Welding head SATP-80X Ø10 to Ø78 mm Supplied with wire dispenser	7.5 kg	0.8 mm	200 cm/min	85153 10000	451 x 182 x 210

