



The ECO Cutting range 81M - 121ECO - 171ECO



For 20 years AXXAIR has been developing and offering scalable, flexible and reliable machines with many functions based on a patented concentric clamping system.

The frames of our cutting machines 122 - 322 (page 9-11) can be fitted with a cutting motor, a bevelling motor or with a TIG welding torch.

Our ECO range differs from this concept; it only offers a pipe cutting function for customers searching for alternatives.

We developed the ECO cutting range in order to respond to these users looking simply for a cutting solution for thin tubes.

Machines dedicated to thin tubes <3 mm wall thickness

Easy to transport and less heavy

Attractive prices

METABO motorisation offers a large speed range and a torque big enough for thin stainless steel tube applications. This motor also has a handle that gives the possibility for the motor to be turned manually around the machine.

The design of the 121ECO and the new 171ECO, has the same system to set diameters and blade penetration as our range x22.

Thus, these machines benefit from very performing characteristics and a design especially made for our evolutive range.

Our Eco range does not come with accessories such as rotation autoline and automatic electric clamping.



For more details, accessories and the references please see pages 7 et 8 of this catalogue.





81M - 121ECO - ^{NEW} 171ECO

AXXAIR
INNOVATIVE ORBITAL SOLUTIONS



No tube deforming
Concentric clamping system



Basic and extra stainless steel jaws: no pollution of the pipes

Operator safety feature
Penetration check feature

Limited vibration and tube distortion
Optimized blade-jaws distance

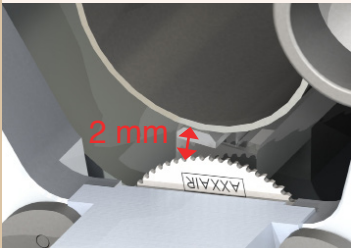

2 mm

Elbow Cutting
121ECO + 171ECO: double shafted cutting motor with 2 blade positions

Motor 1300W
Adjustment via the speed changer

Cutting capacity:
Up to 5 mm wall thickness



Cutting precision
Perpendicular cuts < 0.25 mm

Continuous use
Anti twist cable

Easy handling and transportation



Cutting range	
81M	ø5 - ø78 mm 0.25 - 3 "
121ECO	ø5 - ø121 mm 0.25 - 4.5 "
171ECO	ø16 - ø170 mm 0.625 - 6.625 "





81M - 121ECO - 171ECO

AXXAIR
INNOVATIVE ORBITAL SOLUTIONS

Technical features :

METABO motorisation offers a large range of speed and an adequate torque for thin wall stainless steel tubes applications.

Electric motor 1300W:

- Mechanical gearbox and electric speed variator
- 50/60 HZ
- single-phase motor

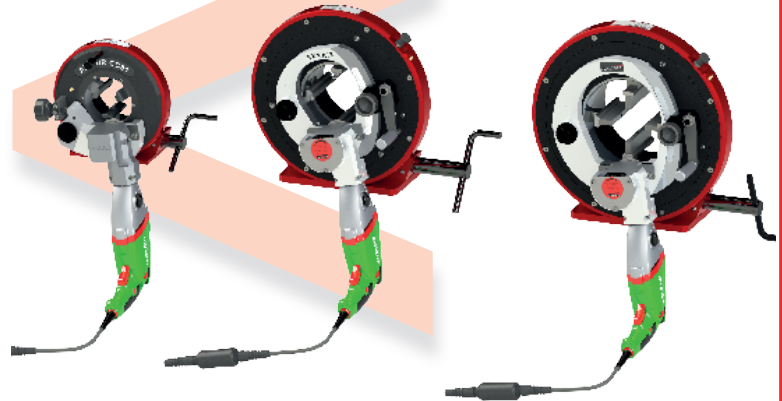

All motors are delivered in their individual case, including the necessary tools

The 81M's motor and its necessary tools are put directly in the transport box.

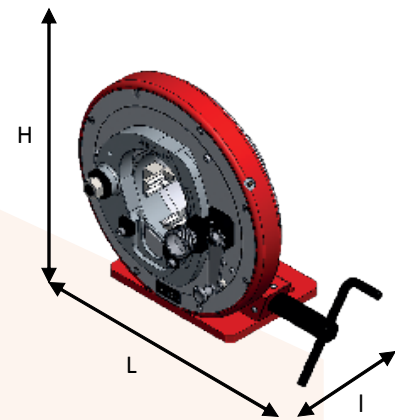

	Reference	Tube cutting machine for following diameters (in mm):		Net weight	Customs Code	Dimensions (HxLxw in mm)
		With basic jaws	With extra jaws (included)			
120V 1300W	81M11	Ø5 - Ø78	-	15 kg	846150 9000	263 x 346 x 236
	121ECO1	Ø24 - Ø121	Ø5 - Ø108	38 kg		432 x 520 x 297
	NEW 171ECO1	Ø70 - Ø170	Ø16 - Ø118	44 kg		453 x 550 x 307
230V 1300W	81M21	Ø5 - Ø78	-	15 kg	846150 9000	263 x 346 x 236
	121ECO2	Ø24 - Ø121	Ø5 - Ø108	38 kg		432 x 520 x 297
	NEW 171ECO2	Ø70 - Ø170	Ø16 - Ø118	44 kg		453 x 550 x 307



Join **experience**

