

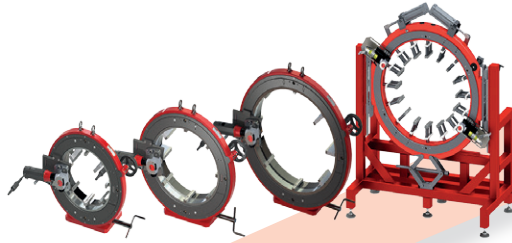

421- 521-721-1100

AXXAIR
INNOVATIVE ORBITAL SOLUTIONS



No tube deforming

Concentric clamping system

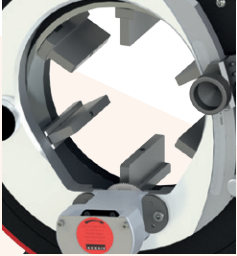

Basic and extra stainless steel jaws: no pollution of the pipes

Elbow cutting

Double shafted cutting motor with 2 blade positions

Cutting quality

Rotation handle for controlled and continuous cutting speed

Vibration reduction and increase in blades lifecycle

Optimized blade-jaws distance

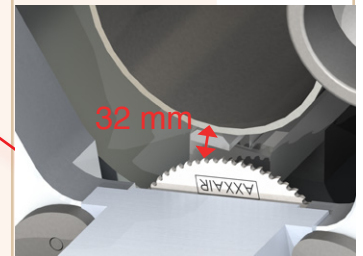

Continuous use

Anti-twist cable

Cutting precision

Perpendicular cuts < 0.4 mm

Easy handling and transportation

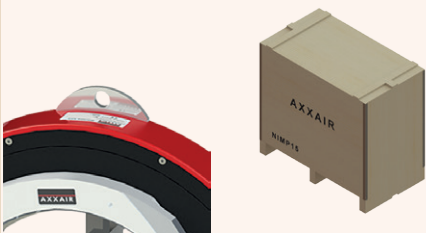

1200W motor or pneumatic motor
(user's choice)

Cutting capacity:
Up to 7 mm wall thickness

Cutting range

421	ø212 - ø422 mm 8.625 - 16 "
521	ø312 - ø522 mm 12.75 - 20 "
721	ø447 - ø725 mm 18 - 28"
1100	ø711 - ø1016 mm 28 - 40 "





421-521-721-1100

AXXAIR
INNOVATIVE ORBITAL SOLUTIONS

Technical features:

- Fast motor:

120V or 230V, 1200W, electronic speed variator with torque compensator

Vibration level according to EN 28662 norm : <math>< 2.5m/s^2</math>, protection class : IP 20

- Pneumatic motor:

60 to 110 rpm, air flow rate 1500 l/min at 6 bar

All motors are delivered in their individual case, including the necessary tools

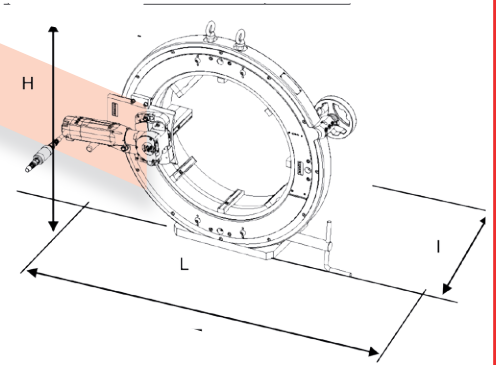

	Reference	Tube cutting machine for following diameters (in mm):		Net weight	Customs Code	Dimensions (HxLxw in mm)
		With basic jaws	With extra jaws (included)			
120V 1200W fast motor	421FS19	Ø350 - Ø422	Ø212 - Ø352	186 kg	84615 09000	802x838x315
	521FS19	Ø450 - Ø522	Ø312 - Ø452	223 kg		905x889x315
	721FS19	Ø653 - Ø725	Ø447 - Ø654	256 kg		1104x1077x315
230V 1200W fast motor	421FS29	Ø350 - Ø422	Ø212 - Ø352	186 kg	84615 09000	802x838x315
	521FS29	Ø450 - Ø522	Ø312 - Ø452	223 kg		905x889x315
	721FS29	Ø653 - Ø725	Ø447 - Ø654	256 kg		1104x1077x315
Pneu- matic motor	421PD	Ø350 - Ø422	Ø212 - Ø352	186 kg	84615 09000	802x838x315
	521PD	Ø450 - Ø522	Ø312 - Ø452	223 kg		905x889x315
	721PD	Ø653 - Ø725	Ø447 - Ø654	256 kg		1104x1077x315
	1100	On demand				

